

| Part # | Tooth Count | Pitch Diameter (ref) | Outer Diameter | Inner Width | Overall Width |
|----------|-------------|----------------------|------------------|------------------|------------------|
| WCP-1420 | 15 | [23.87] 0.940 | [28.00] 1.102 | [10.29] 0.405 | [14.29] 0.563 |
| WCP-0562 | 15 | [23.87] 0.940 | [28.00] 1.102 | [19.05] 0.750 | [22.23] 0.875 |
| WCP-0563 | 18 | [28.65] 1.128 | [32] 1.260 | [10.29] 0.405 | [14.29] 0.563 |
| WCP-0991 | 18 | [28.65] 1.128 | [32] 1.260 | [18.23] 0.718 | [22.23] 0.875 |
| WCP-0564 | 24 | [38.20] 1.504 | [42] 1.654 | [10.29] 0.405 | [14.29] 0.563 |
| WCP-0992 | 24 | [38.20] 1.504 | [42] 1.654 | [18.23] 0.718 | [22.23] 0.875 |
| WCP-0565 | 30 | [47.75] 1.880 | [51] 2.008 | [10.29] 0.405 | [14.29] 0.563 |
| WCP-0993 | 30 | [47.75] 1.880 | [51] 2.008 | [18.23] 0.718 | [22.23] 0.875 |
| WCP-0990 | 36 | [57.30] 2.256 | [60] 2.362 | [10.29] 0.405 | [14.29] 0.563 |
| WCP-0994 | 36 | [57.30] 2.256 | [60] 2.362 | [18.23] 0.718 | [22.23] 0.875 |

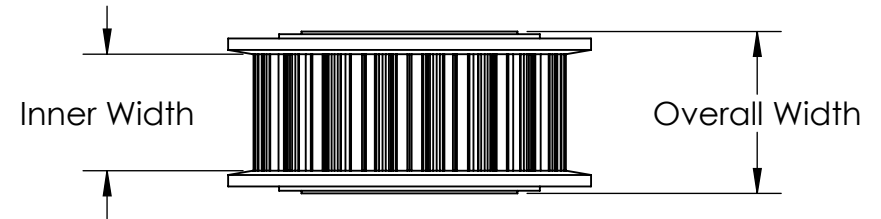
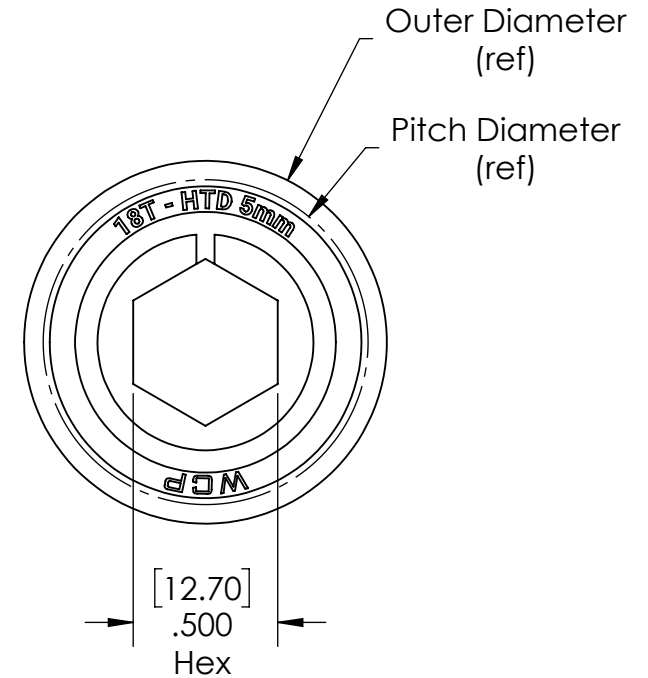

| | | | |
|-------------|--|------------------------|---|
| Description | | 5mm HTD Timing Pulleys | |
| Dwg No | | 5mm HTD Timing Pulleys | |
| Project | | FIRST Robotics - FRC | Sheet 1 of 1 |
| Release | | 1/5/2024 | ALL DIMENSIONS ARE IN INCHES [MM]. |

WWW.WCPRODUCTS.COM

| Part # | Tooth Count | Pitch Diameter (ref) | Outer Diameter | Inner Width | Overall Width | Bore |
|----------|-------------|----------------------|----------------|------------------|------------------|---------|
| WCP-0076 | 12 | [19.10] 0.752 | [23] 0.906 | [11] 0.433 | [14.50] 0.571 | 8mm Key |
| WCP-0077 | 12 | [19.10] 0.752 | [23] 0.906 | [18.50] 0.728 | [22] 0.866 | 8mm Key |
| WCP-0454 | 12 | [19.10] 0.752 | [23] 0.906 | [14.94] 0.588 | [19.05] 0.75 | Falcon |
| WCP-0319 | 12 | [19.10] 0.752 | [23] .906 | [26.50] 1.043 | [30.1] 1.185 | Falcon |

Note:
 (1) WCP-0076 Rev1 and WCP-0077 Rev1 have 8mm round bore with a 2mm keyway. WCP-0319 and WCP-0454 have a 14T Spline bore.

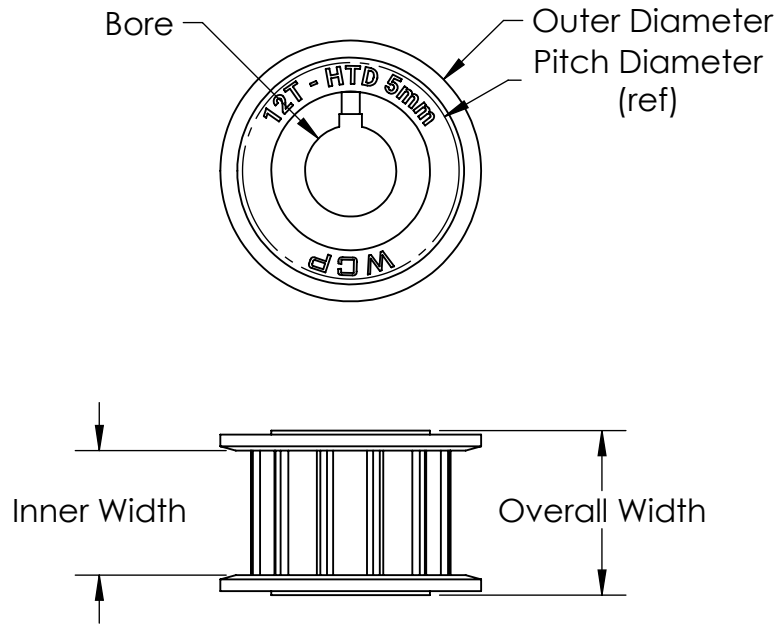

| | | | |
|-------------|----------|---|--------------|
| Description | | 5mm HTD Timing Pulleys | |
| Dwg No | | 5mm HTD Timing Pulleys | |
| Project | | FIRST Robotics - FRC | Sheet 1 of 1 |
| Release | 1/5/2024 | ALL DIMENSIONS ARE IN INCHES [MM]. | |