

Greyt Turret (5-7") - User Guide (Rev 1)

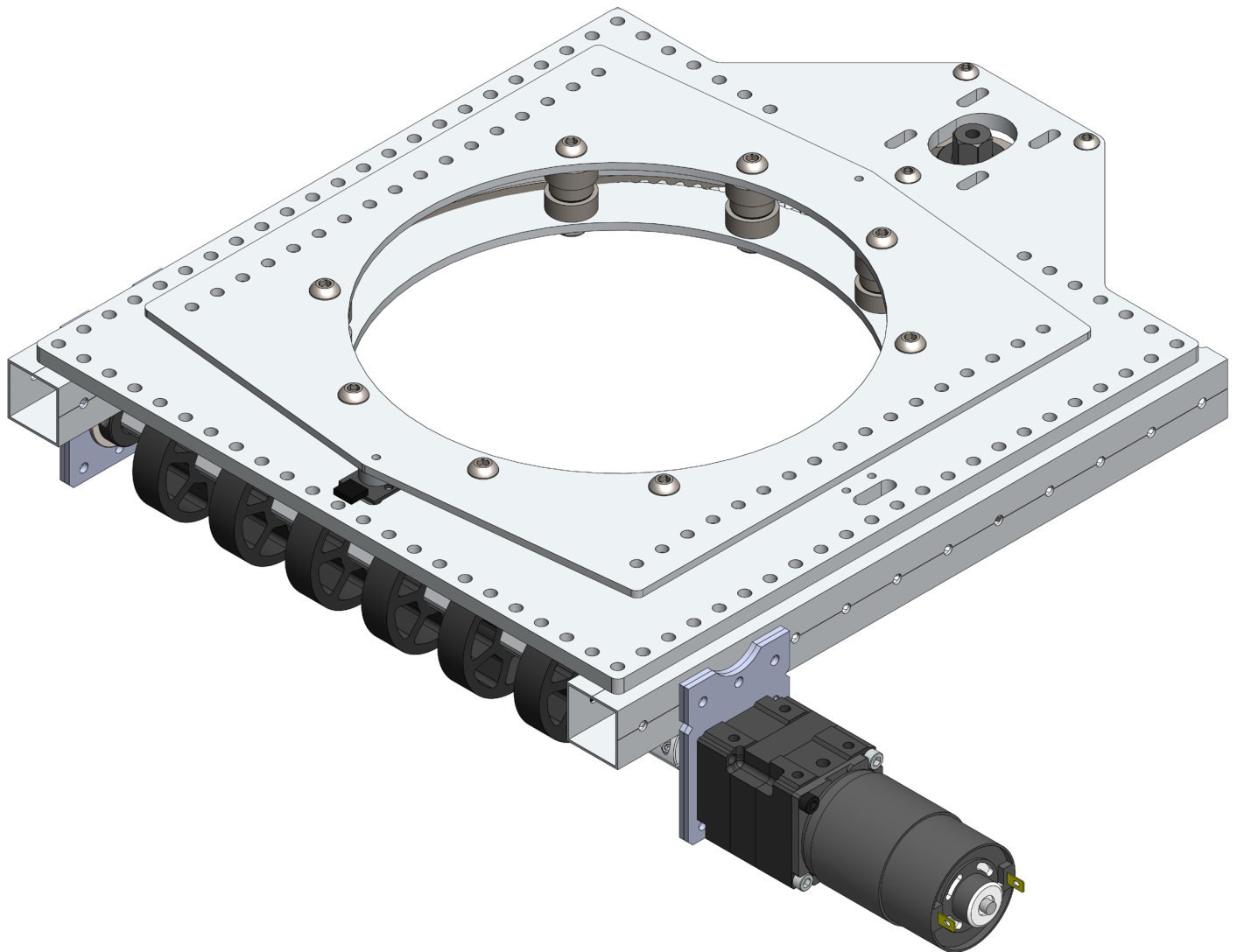



Table of Contents

What is the Greyt Turret (5-7") ?	3
Greyt Turret Assembly Instructions	5
Step 1	6
Step 2	7
Step 3	8
Step 4	9
Step 5	10
Step 6	11
Step 7	12
Preroller Assembly Instructions	13
Step 1	14
Step 2	15
Step 3	16
Step 4	17
Kit Contents	18
Recommended Parts to Buy	20
Turret Preroller	22
Application Example - 2020 WCP CC	24
FAQ	25
Trouble Shooting	25
Revision Table	26



What is the Greyt Turret (5-7") ?



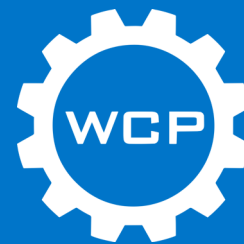

The GreyT turret builds on the elevator and roller claw released previously. This mechanism is designed to help teams create high strength turrets easily. This turret is compatible with the GreyT Shooter.

The main features of this Turret are:

- Smooth Rotation
- Compatible with VersaPlanetary
- Built in Tensioner
- Integrated Roller
- Compatible with GreyT Shooter



Recommended Tools

Picture	Name
	Allen Wrench Set
	3/8" Wrench
	7/16" Wrench
	#25 Chain Tool



Greyt Turret Assembly Instructions

The following will cover the basic assembly instructions for the Greyt Turret.

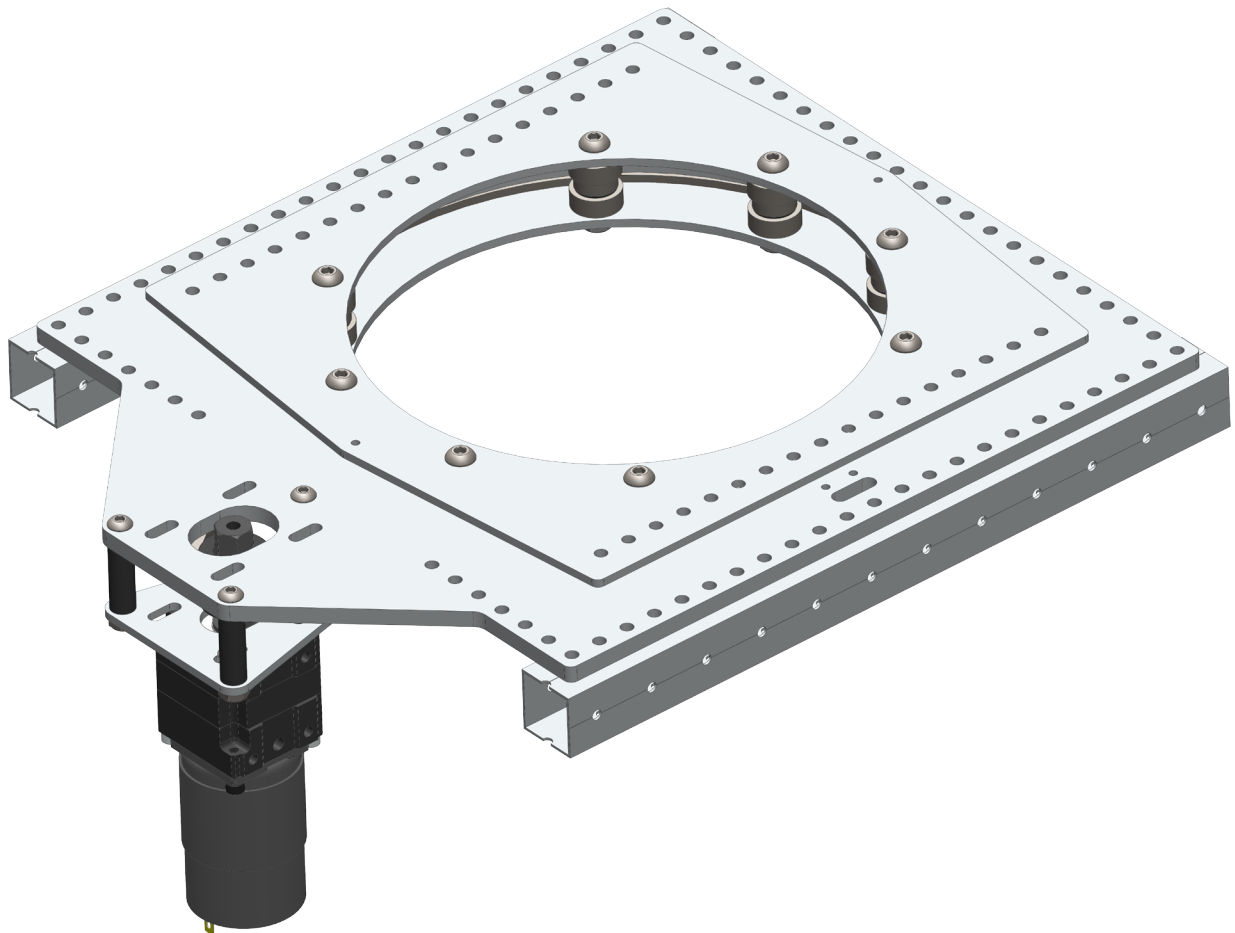



Step 1

Slide the #1/4-20 x 1.375"L bolt into one of the bearing bolt holes. Install the bearings and washers as seen below. There should be a washer between each bearing and between the bearing and plate.

Repeat this step in the remaining seven bearing bolt holes.

While assembling the parts in this step, use a piece of tape to hold the head of the bolt in place so that the bolt does not fall out. This will also help in future steps.

Note: Failure to install the washers will greatly increase the friction in the system and may result in the turret not being able to rotate.

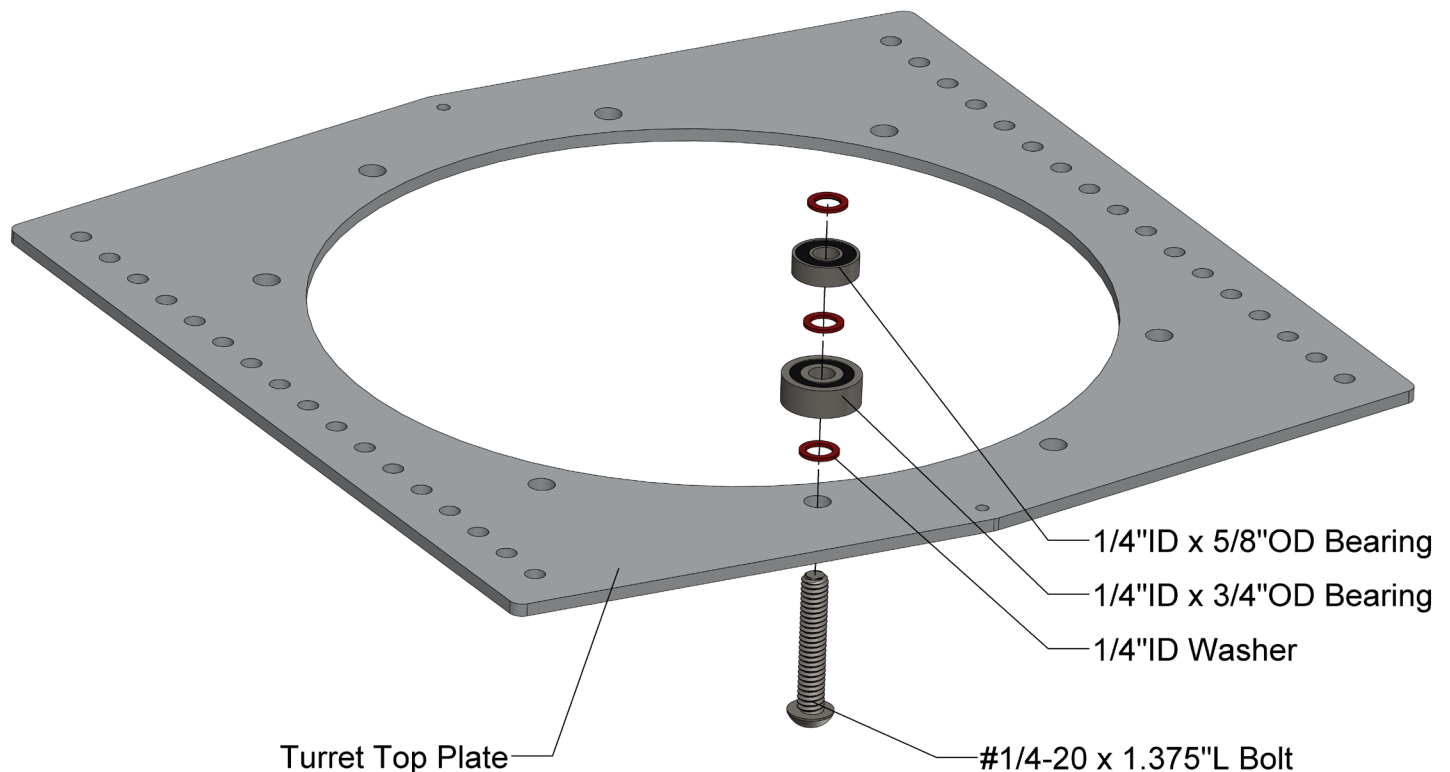



Step 2

Rest the turret mounting plate on the 1/4"ID x 3/4"OD bearings. The 1/4"ID x 5/8"OD bearings should be resting on the inside face of the large cutout circle.

Note: The turret mounting plate will come as two 1/8" aluminum plates. These plates may be bolted together. They will function the same as one 1/4" aluminum plate.

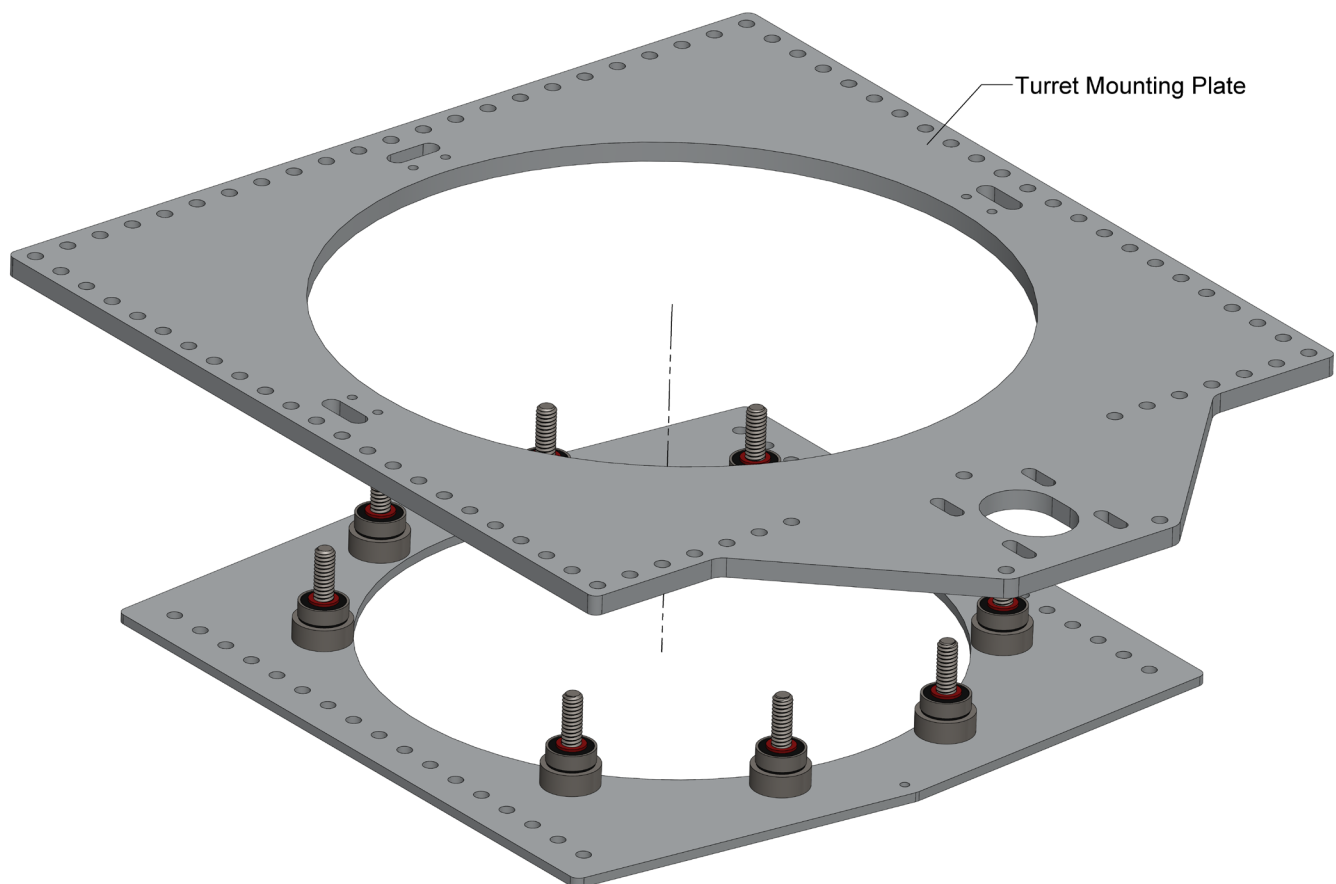



Step 3

Install the final 1/4"ID x 3/4"OD bearing and washer on each of the bolts.

Note: Failure to install the washers will greatly increase the friction in the system and may result in the turret not being able to rotate.

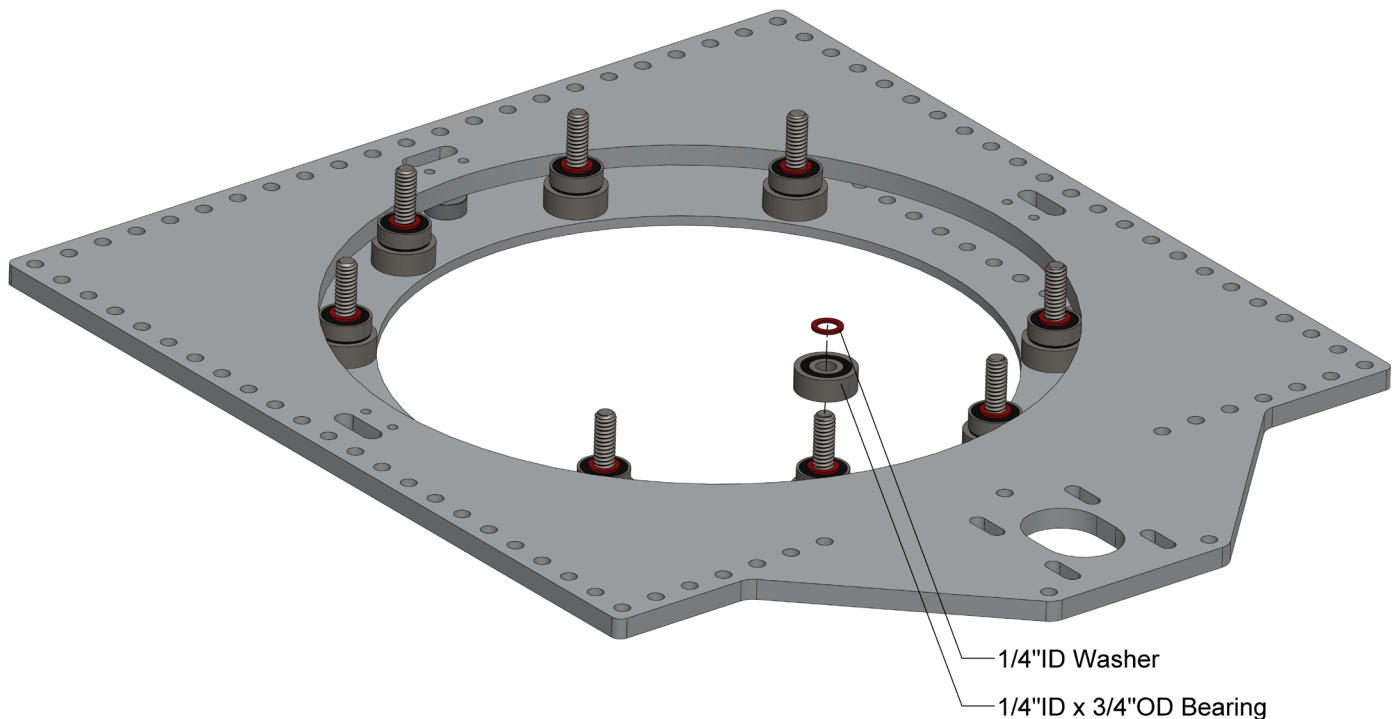



Step 4

Align holes in the turret sprocket with all bolts and slide the sprocket on. Install all nuts.

Tighten all the bolts until there is no wiggle in the bolts. The bolts should not be able to move but not so tight as to prevent the turret from spinning.

If the turret does not spin, find the tightest bolt and loosen it a 1/4 turn. Repeat this process until the turret spins smoothly.

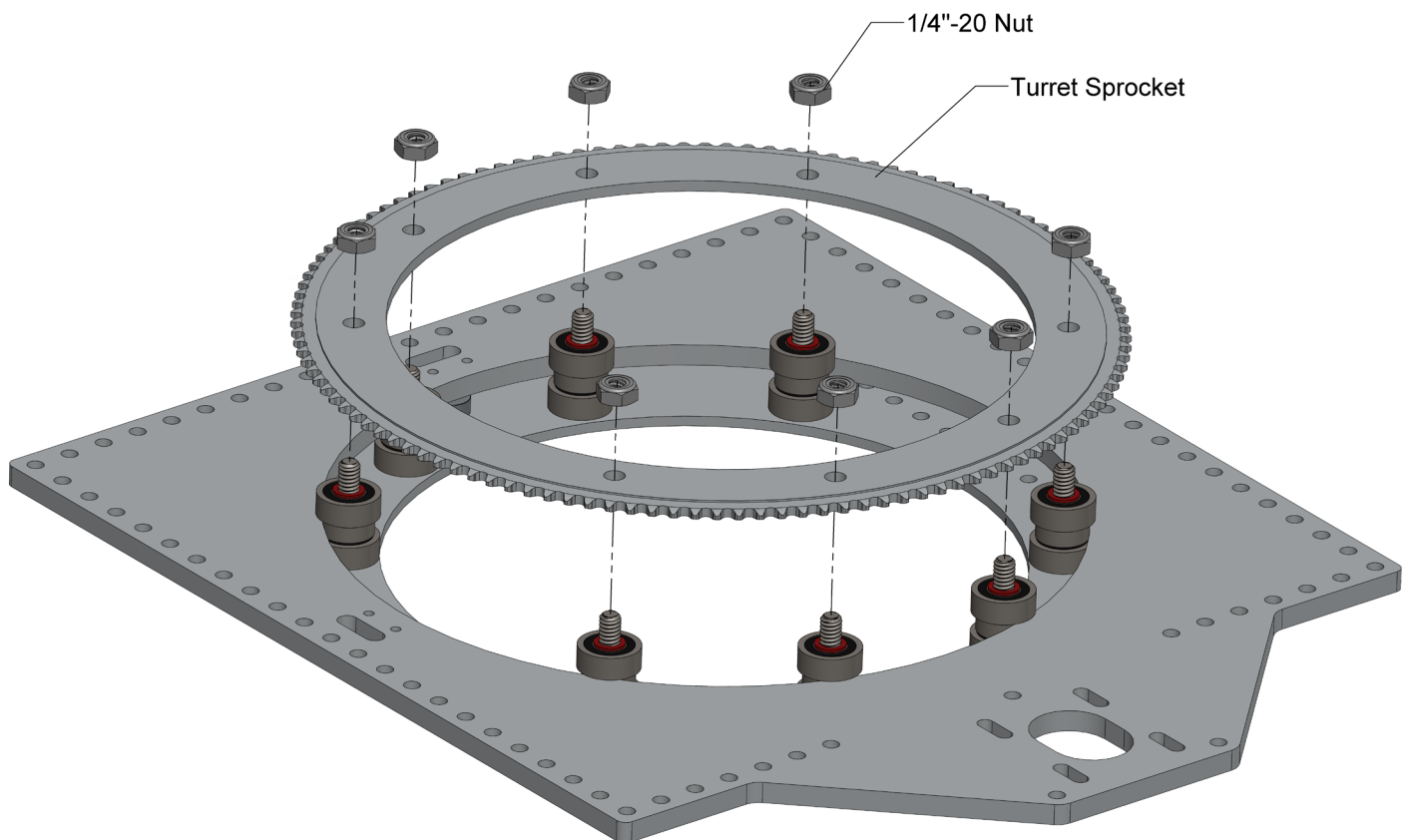



Step 5

Install the spacers and VP mounting plate first. One of the bolts will use the WCP Cam as a nut. The other two will use nuts.

As the VersaPlanetary is installed, slide the sprocket and two collars onto the output shaft. Lightly tighten the mounting bolts since the chain will still need to be tensioned.

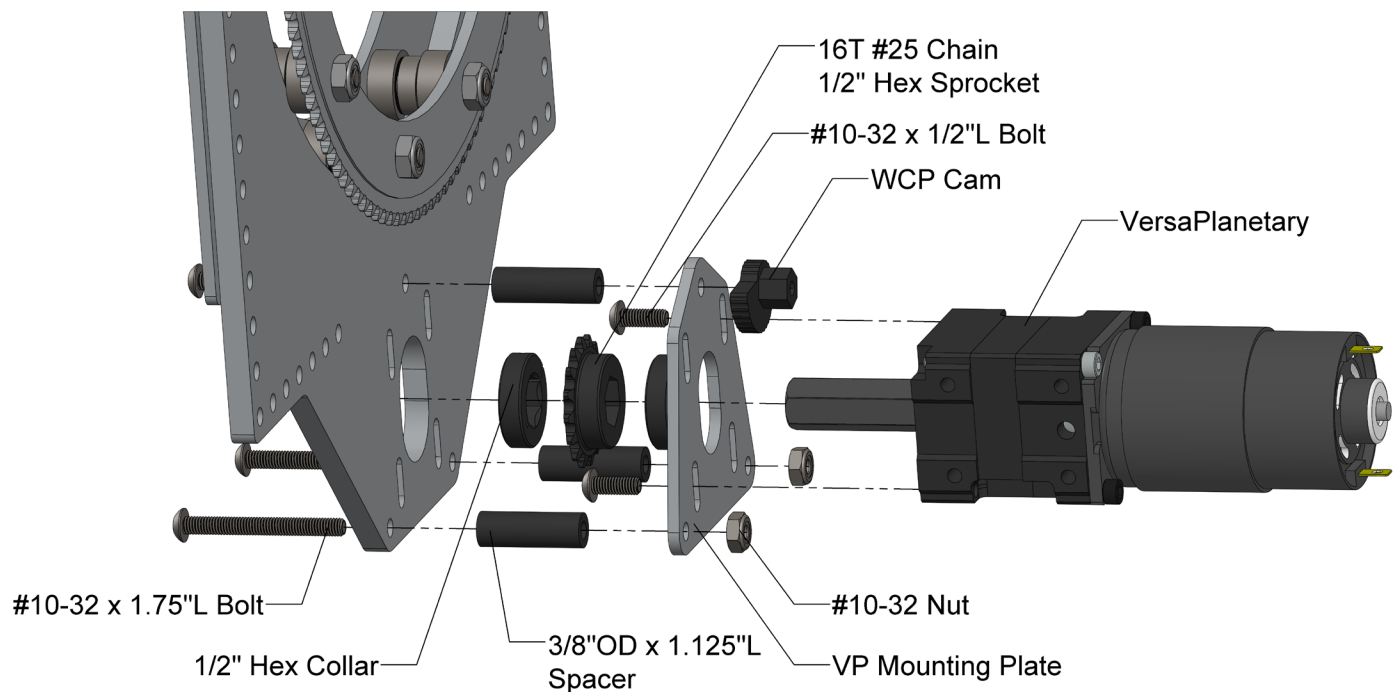



Step 6

Loop the #25H chain onto the sprockets. Make the chain as short as possible when the VersaPlanetary is as close as possible to the large sprocket.

Tighten the chain using the WCP Cam and tighten bolts when chain is tight.

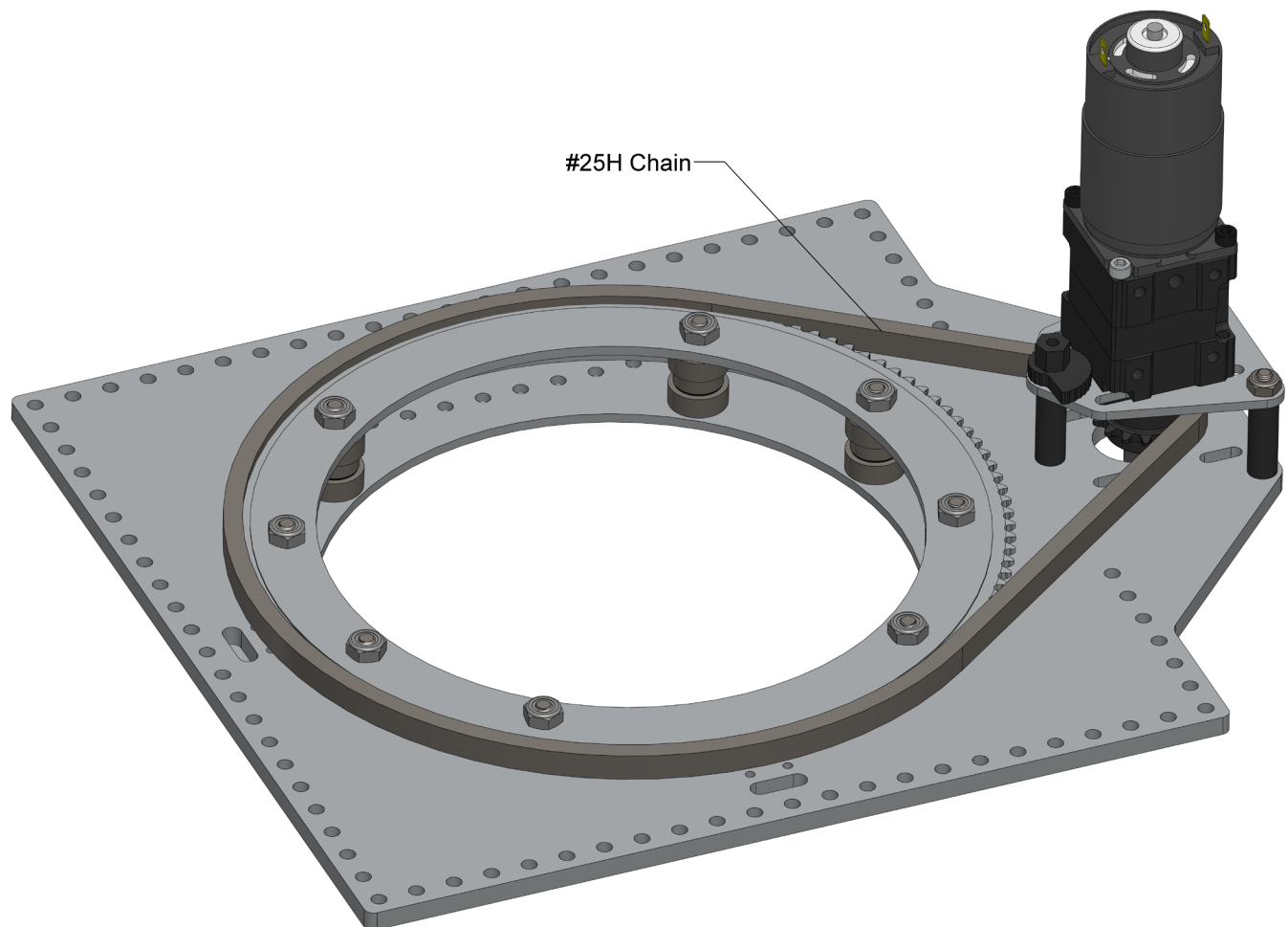



Step 7

Bolt the turret to the mounting tubes or other support structure.

Note: This view is from the bottom of the turret.

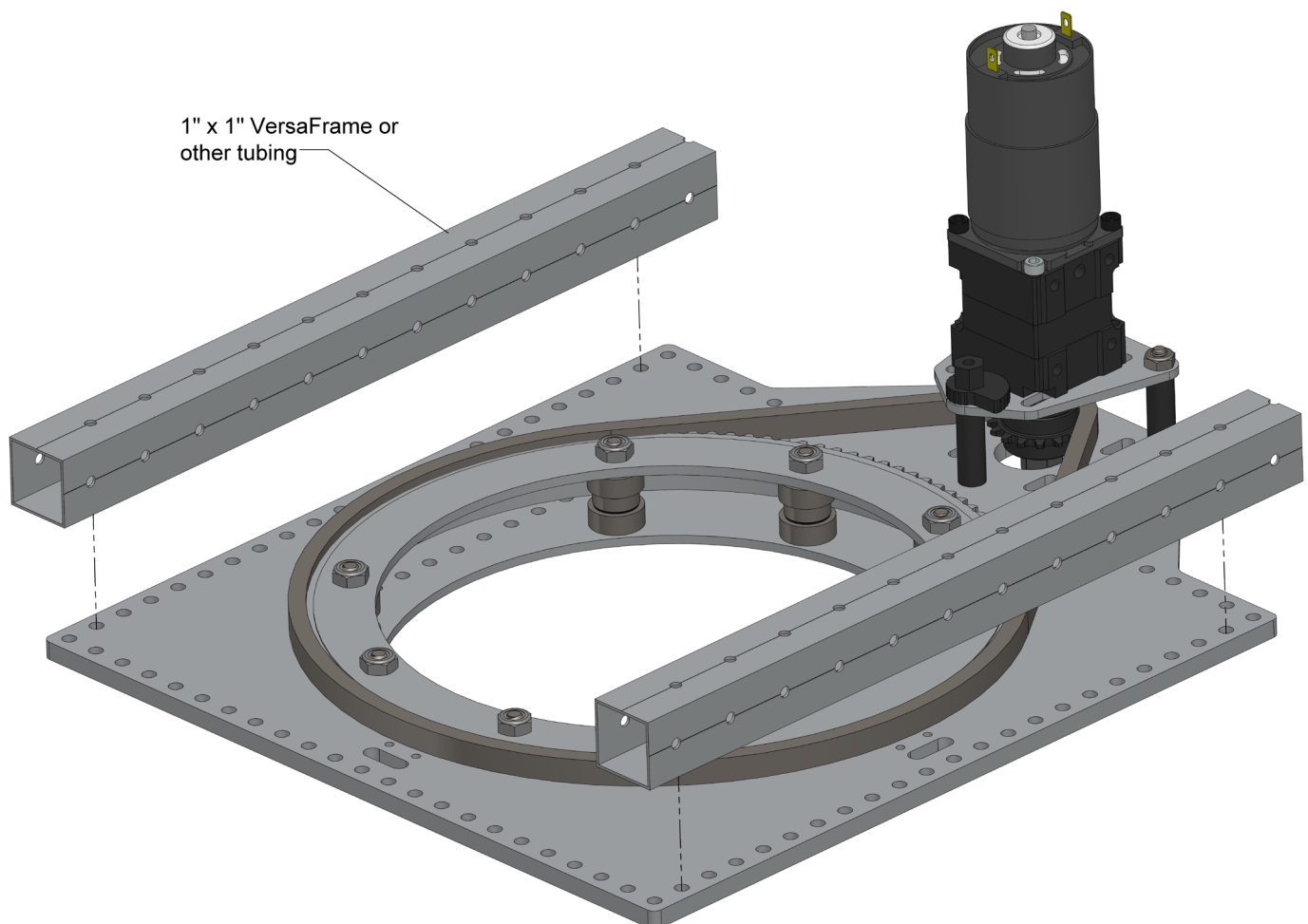



Preroller Assembly Instructions

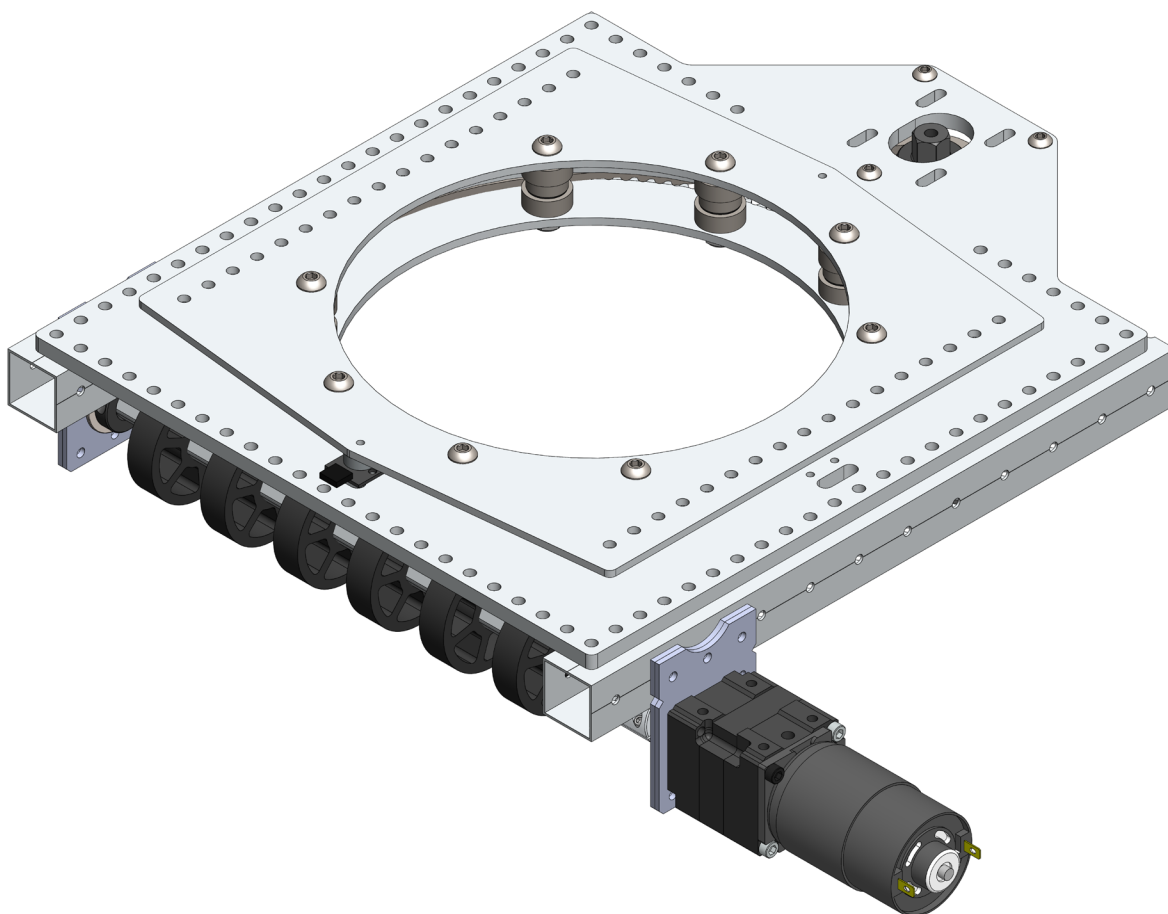



Step 1

Pre-cut the extra material off the Bearing Mounts before installation. These may be bolted or riveted on.

For extra support, two plates per side are recommended.

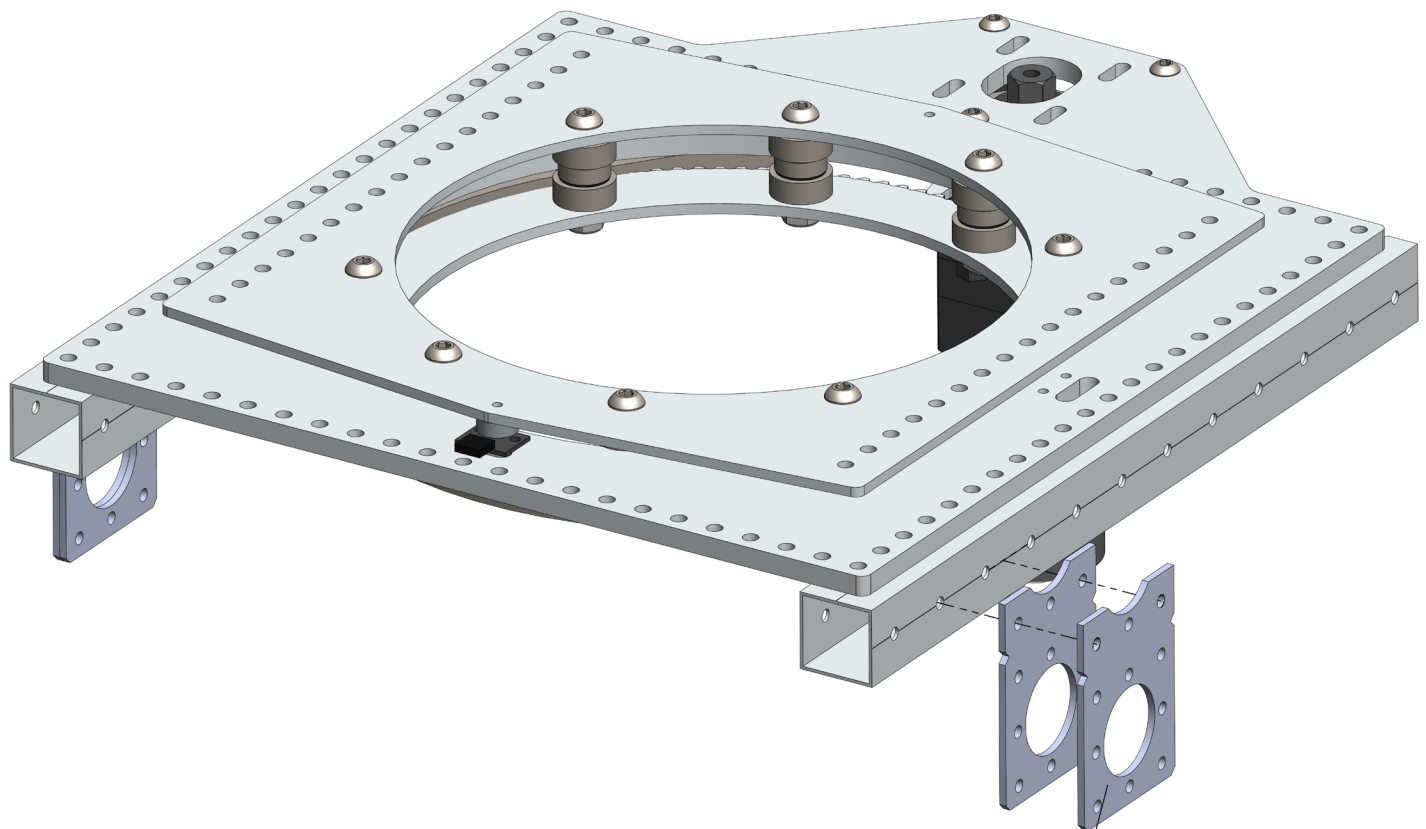

VersaFrameFace Bearing Mount
(will need to be cut for clearance)



Step 2

Slide one 1/2" ThunderHex Bearing into the side of the turret that will not have the Ver-saPlanetary.

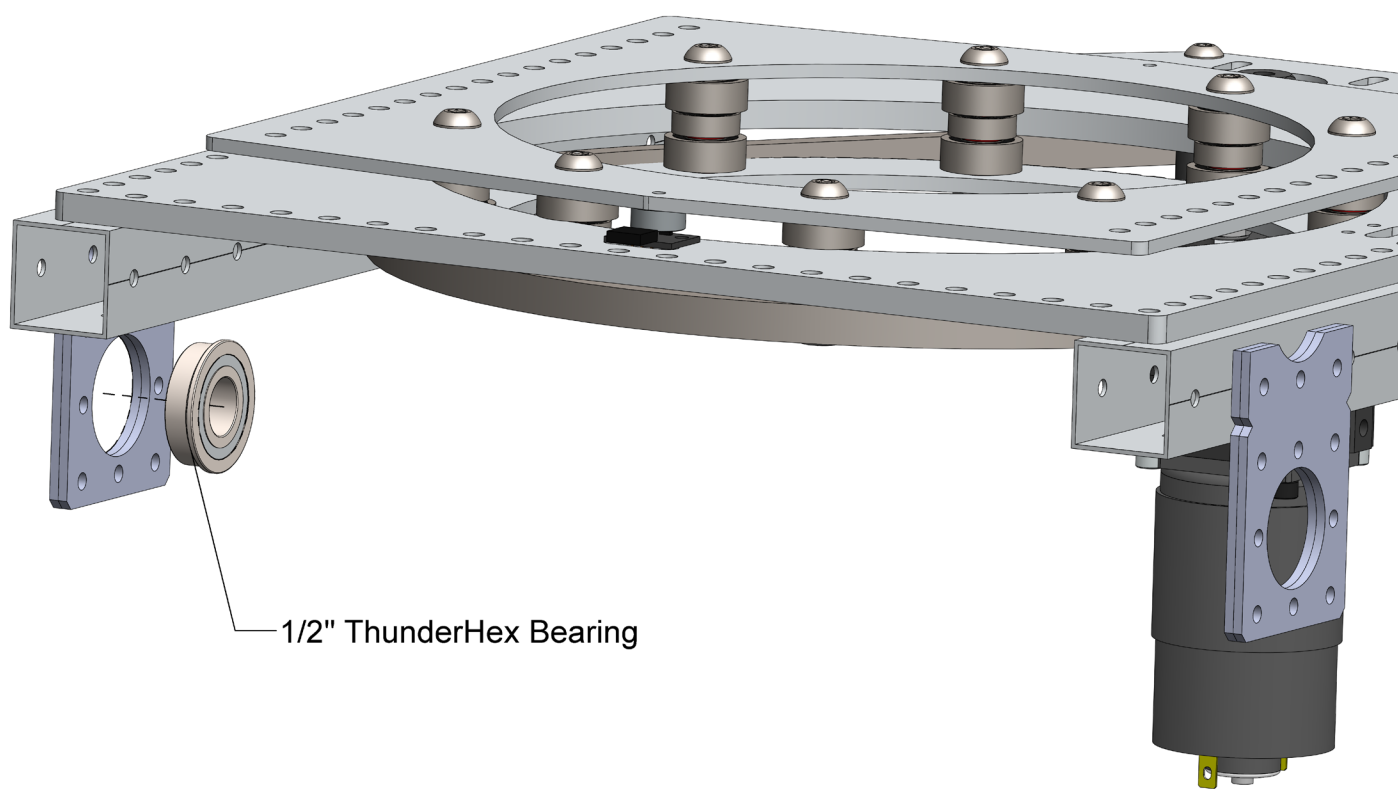



Step 3

Bolt the VersaPlanetary into place using two #10-32 bolts.

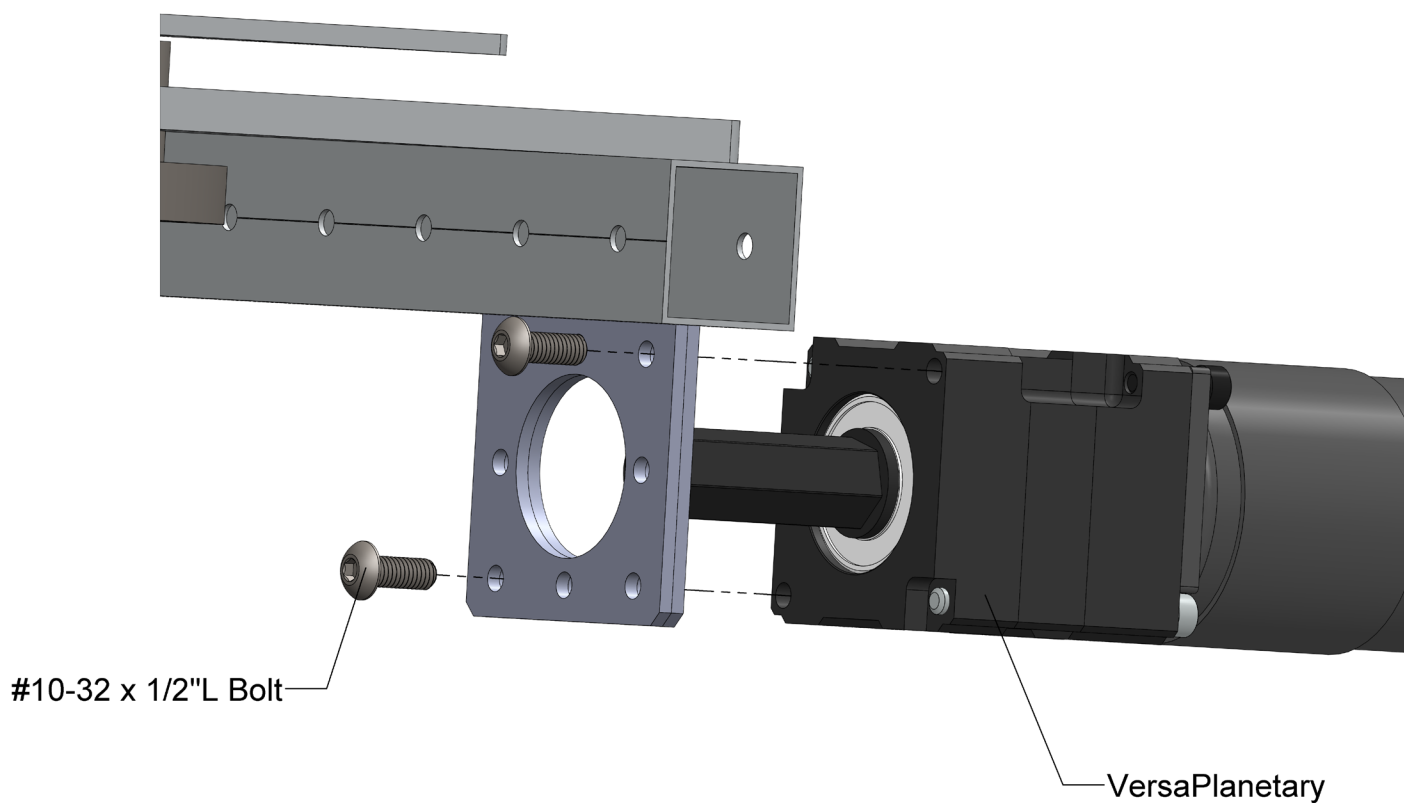



Step 4

Slide the ThunderHex shaft through the ThunderHex bearing and add desired amount of 2"OD Flexwheels.

Use shaft collars and the 1/2" Hex Coupler to constrain shaft.

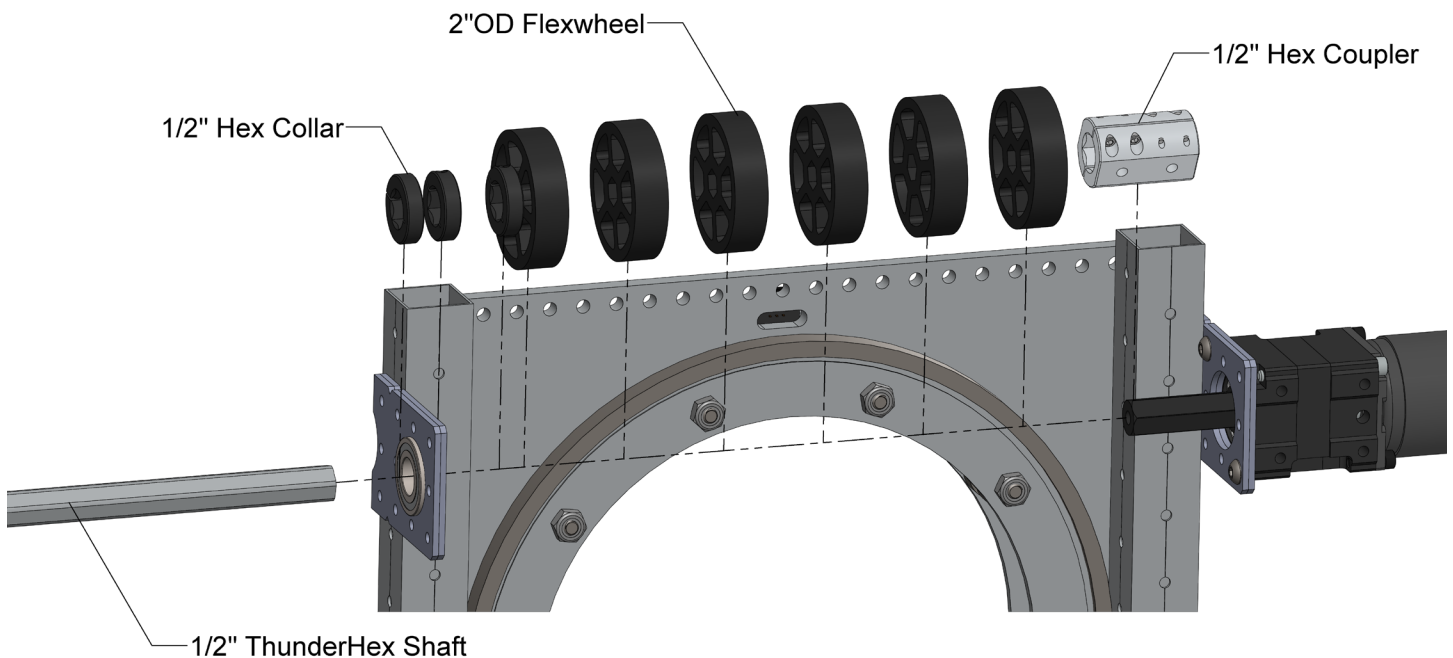



Kit Contents

Picture	Name	QTY	Kit
	Turret Mounting Plate	2	Base Kit
	Turret Top Plate	1	Base Kit
	Turret Sprocket	1	Base Kit
	VersaPlanetary Mounting Plate	1	Base Kit
	1/4"-20 x 1.5"L Bolt	8	Base Kit

Greyt Turret (5-7") - User Guide (Rev 1)

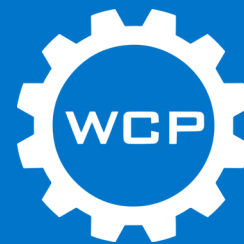

Picture	Name	QTY	Kit
	1/4"-20 Nut	8	Base Kit
	#10-32 x 1.75"L Bolt	3	Base Kit
	#10-32 Nut	2	Base Kit
	1/4" Washer	32	Base Kit
	#10-32 x 1/2"L Bolt	2	Base Kit



Recommended Parts to Buy

Picture	Name	QTY
	#25H Chain	1
	#25 Chain 16T 1/2" Hex Sprocket	1
	VersaPlanetary w/ Required Gear and Ring Kit	1
	1/2" Hex Collar	2
	3/8"OD x 1.125"L Aluminum Spacer (5 Pack)	1

Greyt Turret (5-7") - User Guide (Rev 1)



Picture	Name	QTY
	WCP Cam	1
	1/4"ID x 3/4" OD Radial Bearing	16
	1/4"ID x 5/8"OD Radial Bearing	8

Greyt Turret (5-7") - User Guide (Rev 1)



Turret Preroller

Picture	Name	QTY
	2"OD Flex Wheel	6 to 17
	1/2" Hex Collar	3
	VersaFrame Face Bearing Mount (2-pack)	2
	VersaPlanetary w/ Required Gear and Ring Kit	1
	1/2" ThunderHex Bearing	1

Greyt Turret (5-7") - User Guide (Rev 1)



Picture	Name	QTY
	1/2" Hex Coupler	1
	1/2" ThunderHex (36")	1



Application Example - 2020 WCP CC

The 2020 WCP CC utilized the Greyt turret to for aligning with the target in the 2020 FRC game Infinite Recharge. The turret was used in combination with the Greyt Shooter and the Limelight 2+. This combination is simple to use and combine for a robust scoring system. The turret can also be used as a stand alone assembly that teams can add their own mechanisms too.

CAD and video of the 2020 WCP CC can be found here:
<https://www.wcproducts.com/cc/>

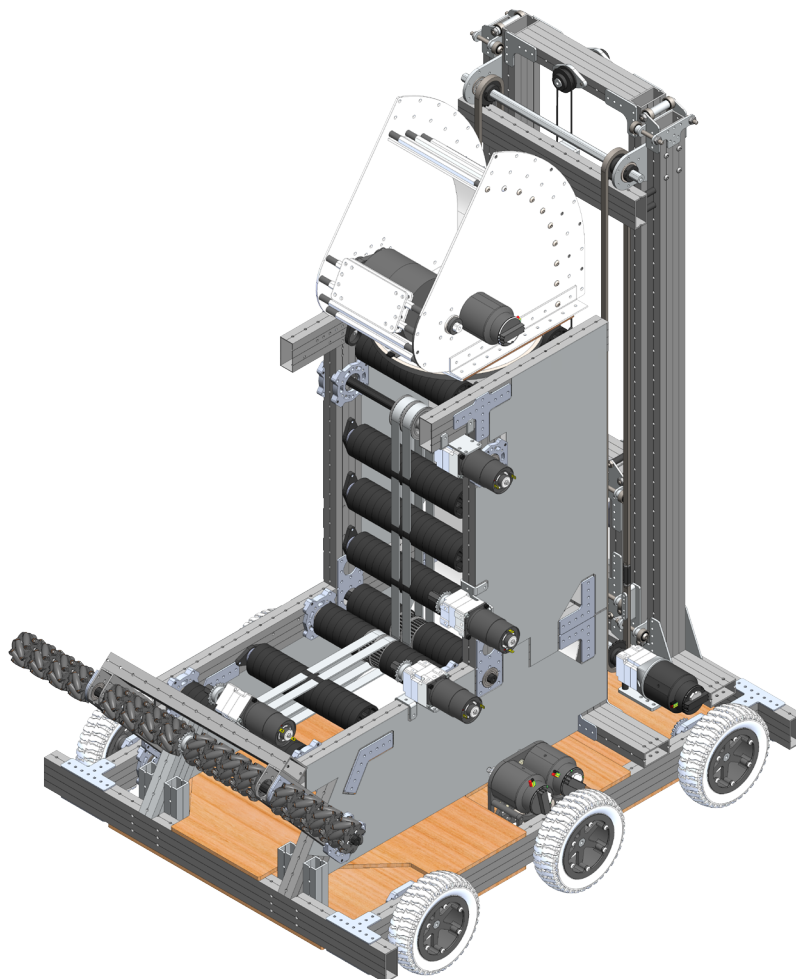



FAQ

Q: Are the washers between the bearings needed?

A: Yes, these washers are required. They prevent the bearings from rubbing against each other. This may cause the turret to not rotate or be hard to rotate, even by hand.

Trouble Shooting

Issue: Chain falls of the sprocket or is skipping

Possible Solutions:

1. Ensure that the sprocket on the VersaPlanetary output shaft is aligned horizontally with the turret sprocket. The collars that hold the 16T sprocket in place should also be tight. The sprocket should not be able to move vertically.
2. The chain may not be tight enough on the sprocket and this is causing the chain to skip or fall off. Re-tension the chain using the WCP Cam to move the VersaPlanetary further away from the turret sprocket. Be sure to tighten all bolts that hold the VersaPlanetary in place as well as the bolt for the cam.
3. Due to the manufacturing process, the sprocket profile is machined and not hobbled, some sprockets may have a minimal wear in process. This may cause the chain to pop off the sprocket before the wear in period. It is recommended to run the turret for ~5 mins as a wear in period. After this time, the chain may become loose. It is recommended to re-tension after the wear in period.



Revision Table

Revision Date	Revision #	Description
8/26/2020	1.1	First revision created.